

PEAK 8920VL2

Intel® Dual-Core Xeon® LGA771 Processor with Fully Buffered DIMM/ 2 x PCI Express Gigabit LAN/ 6 x USB

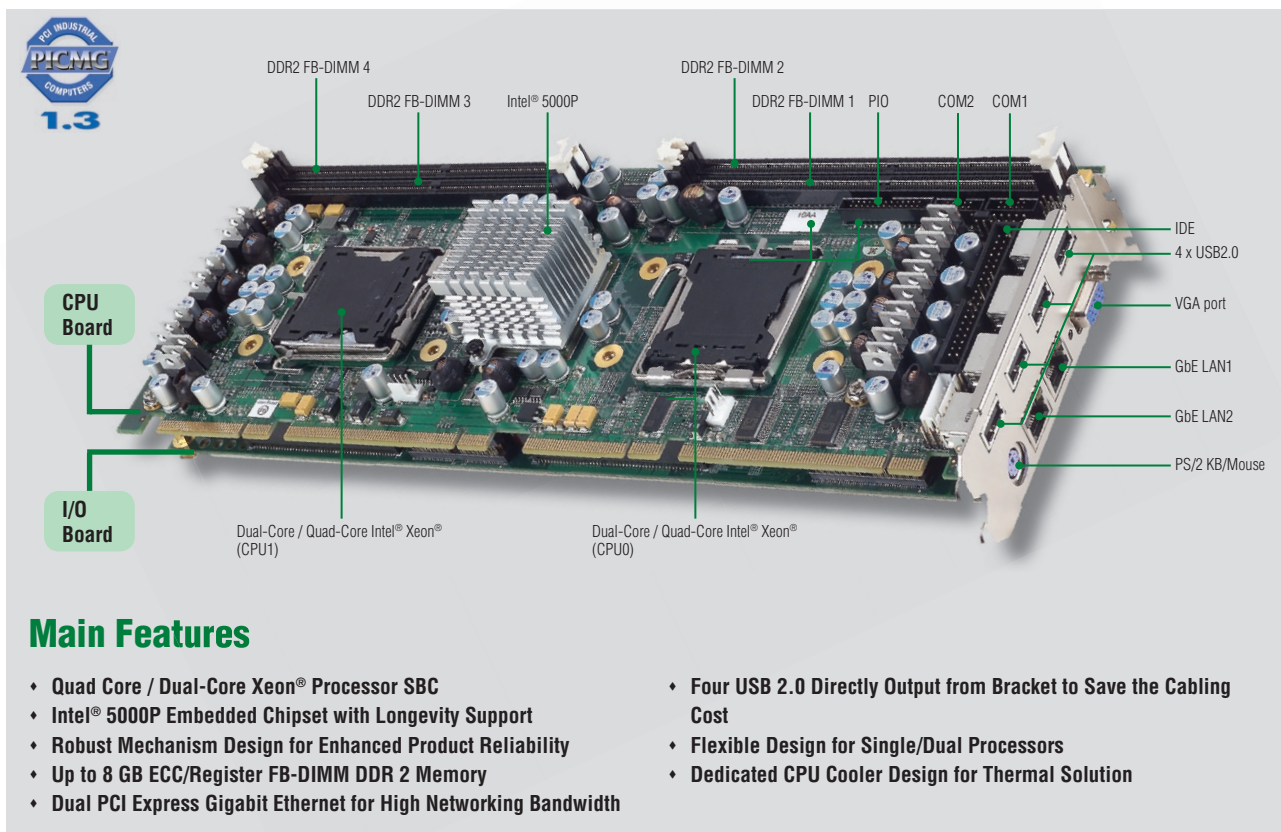

Main Features

- ◆ Quad Core / Dual-Core Xeon® Processor SBC
- ◆ Intel® 5000P Embedded Chipset with Longevity Support
- ◆ Robust Mechanism Design for Enhanced Product Reliability
- ◆ Up to 8 GB ECC/Register FB-DIMM DDR 2 Memory
- ◆ Dual PCI Express Gigabit Ethernet for High Networking Bandwidth
- ◆ Four USB 2.0 Directly Output from Bracket to Save the Cabling Cost
- ◆ Flexible Design for Single/Dual Processors
- ◆ Dedicated CPU Cooler Design for Thermal Solution

Product Overview

The PEAK 8920VL2 supports LGA771 dual-core Quad-core Intel® Xeon® Processor up to 2.33 GHz with 1333 MHz FSB. Featuring an Intel® 5000P Chipset + Intel® ESB2, the PEAK 8920VL2 delivers higher throughput with dual point-to-point system buses, faster memory for I/O bandwidth, and Fully Buffered DIMM (FB-DIMM) support.

The SBC PEAK 8920VL2 is successor to flagship PEAK 7220, which complied with PICMG 1.3 to ensure easy configuration, highest quality standard, and seamless compatibility with products from other manufactures. With the excellent I/O Bandwidth handling, the industrial graded high performance PEAK 8920VL2 is suitable to configure for medical and Gaming.

Specifications

CPU Support

- ◆ Support Dual-Core Intel® Xeon® processor 5100 series and Quad-Core Intel® Xeon® Processor 5300 series (80W)
- ◆ Intel® Embedded Processor List (Intel® Longevity CPU):
Dual-Core Intel® Xeon® Processor (5130 & 5140)
Dual-Core Intel® Xeon® Processor LV (5128, 5138, 5148)
- ◆ 1066/1333 MHz FSB support

Main Memory

- ◆ 4 x 240-pin four channel DDR 2 FB-DIMM
- ◆ Support ECC / Register DDR2 memory up to 8GB

Chipset

- ◆ Intel® 5000P memory controller Hub
- ◆ Intel® 6321ESB I/O controller Hub

BIOS

- ◆ AMI BIOS
- ◆ Plug & Play support
- ◆ Support Soft off, Wake on LAN, Power On by PS2 Keyboard Function Key, RTC alarm Power On
- ◆ Power on after power failure
- ◆ 8M-bit flash ROM

On-board LAN

- ◆ 2 x Intel® 82573L PCI Express Gigabit Ethernet
- ◆ Support Boot From LAN (PXE)
- ◆ Support Wake On LAN (When 5Vsb power available)
- ◆ 2 x RJ45 with LED

Display

- ◆ ATI ES1000 PCI graphic Controller
- ◆ 32MB DDR2 SDRAM VGA Memory
- ◆ 1 x DB15 VGA port

I/O Interface

- ◆ USB 2.0: 4 ports through I/O bracket
- ◆ USB 2.0: 2 ports, with 1x6 JST (2.5mm)
- ◆ Serial port: 2 ports, with 2x5 box-header (2.0mm) support RS-232 only
- ◆ Parallel port: 1 port , with 2x13 box-header (2.0mm), Bi-directional, EPP/ECP
- ◆ PS/2: 1 x Mini-Din Keyboard/Mouse
- ◆ GPIO: Support 4 sets of general purpose I/O each with TTL level (5V) interface
- ◆ FAN: 2 x 4-pin FAN connectors (for CPU coolers)
- ◆ 1 x on board buzzer
- ◆ 1 x 2-pin power on switch / 1 x SMBus 2.0 to Backplane
- ◆ 1 x 2-pin header for reset / 1 x 5-pin header for key lock



Block Diagram

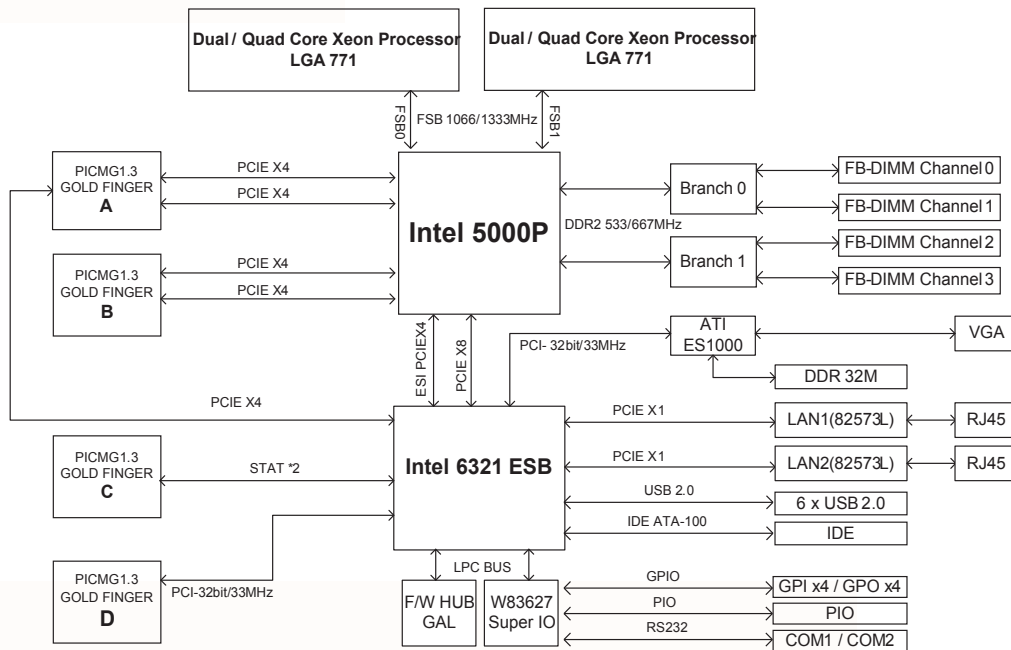

- 1 x 2-pin header for power LED / 1 x 2-pin header for HDD LED

Watchdog Timer

- Watchdog Timer is programmable by software from 0 to 255 seconds (Tolerance 10% under room temperature 25°C)

Storage

- SATA: 2 ports, support RAID 0,1 through Backplane
- IDE: 1 x 40-pin IDE connector, support Ultra ATA 33/66/100
- 1 x 2-pin JST (2.5mm) power connector for DOM (Disk On Module)

System Monitor

- 8 voltage (For +3.3V, +5V, Vcore x2, 1.8V, 1.5V, 5Vsb, and Vbattery)
- 3 temperature (For 2 CPU and system)
- 3 FAN speed monitor (2 for CPU and 1 for ESB2)

On-board RTC

- On-chip RTC with battery back up
- 1 x External Li-Ion battery

Dimensions

- PICMG 1.3 SHB
338.58 mm (L) x 126.39 mm (W) (13.3" x 4.9")

Power Input

- Power source from backplane through PICMG 1.3 Golden Finger, support ATX mode

CPU:2 x Dual-Core Xeon 3.0G Memory:4 x FBD DDR2 2.0GB	+12V	+5V	+3.3V	+5Vsb
Full-Loading Mode	21.4 A	2.07 A	3.85 A	0.04 A
Light-Loading Mode	10.59 A	1.69 A	3.63 A	0.04 A

NOTE:

1. Full Loading: Utilize CPU 100% with Burn-in test running
2. Light Loading: Utilize CPU loading below 5% without data or application running.

Environment

- Operating Temperature: 0°C ~ 60°C (for Board Level Only)
- Storage Temperature: -20°C to 85°C
- Relative Humidity:
Operating: 10%-90% (non-condensing)
Non-Operating: 5%-95% (non-condensing)

Certifications

- CE approval
- FCC Class A

Ordering Information

• PEAK 8920VL2 (P/N: 10P00892000X0)

PICMG 1.3 Full-Size SHB Express (System Host Board), Intel® 5000P Chipset, LGA 771 socket support Dual-Core/Quad-Core Intel® Xeon® processors w/ 4 DDR2 FB-DIMM / 2 Express GbE / 6 USB 2.0 / VGA / 2 SATA.

NEXCOM Backplane Support List

NBP 14111	PICMG 1.3 Passive Backplane 14-slots w/ 1 PICMG 1.3 SHB / 1 PCIe x16 slot / 4 PCI slots / 8 PCI-X slots
NBP 20016	PICMG 1.3 Passive Backplane 20-slots w/ 1 PICMG 1.3 SHB / 16 PCI-X slots

PEAK 8920VL2 Top View

